

Features

- Extremely low RMS period jitter
 - 5 ps (typical)
- Wide frequency range
 - 1 MHz to 220 MHz
- Up to six single-ended CMOS outputs
- Low frequency tolerance
 - ± 25 PPM or ± 50 PPM
- Operating voltage
 - 1.8, 2.5 or 3.3 V
- Operating temperature range:
 - Industrial, -40 to 85°C
 - Extended Commercial, -20 to 70°C
- Small footprint
 - 22-pin, 7.0 x 5.0 x 0.85 mm QFN package
- All packages are Pb-free and ROHs compliant
- Ultra-reliable start up and greater immunity from interference

Benefits

- Replacing up to six crystal oscillators
- No crystal or capacitors required
- Eliminates crystal qualification time
- 50% + board saving space
- More cost effective than quartz oscillators, quartz crystals and clock ICs.
- Completely quartz-free

Applications

- Consumer Electronics Applications
- Automotive Applications
- Industrial Applications
- HDTV, STB, DVD-R, Printer, MFP
- Gigabit Ethernet
- 10 Gigabit Ethernet
- Fibre Channel
- Ethernet
- SATA / SAS
- USB 2.0
- PCI-Express

Block Diagram

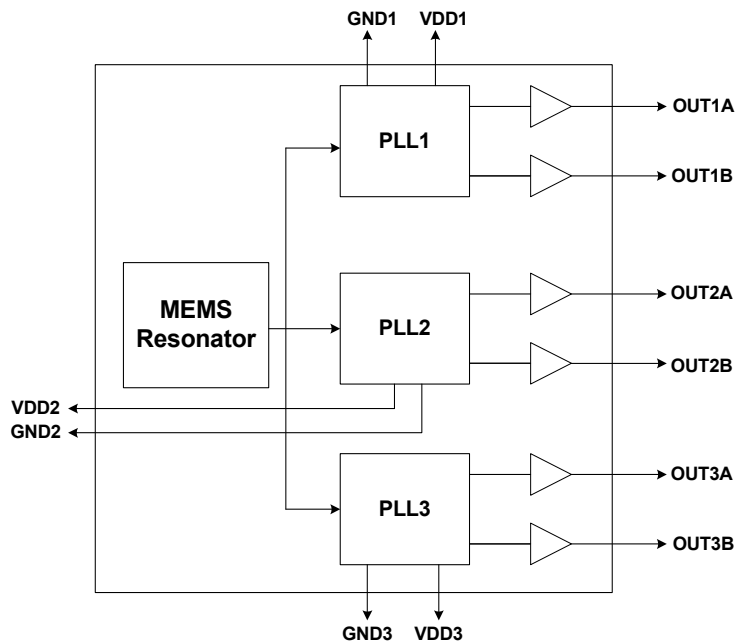

Pinout

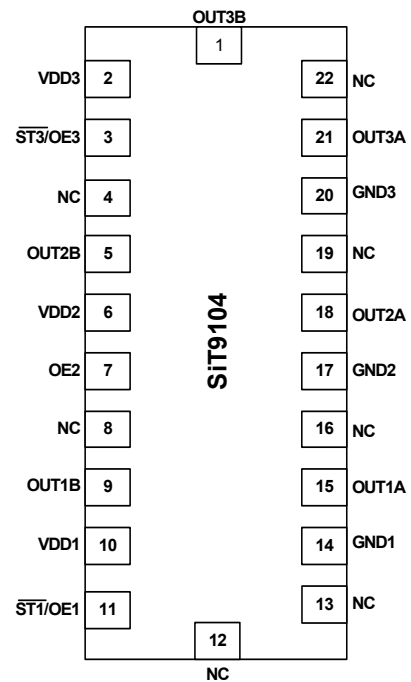

Pin Description

Pin No.	Name	Pin Description
4, 8, 12, 13, 16, 19, 22	NC	Do not connect pins, leave them floating.
1	OUT3B	1 to 220 MHz programmable clock output at VDD3 level (1.8V or 2.5V or 3.3V) or No Connect
2	VDD3	Power supply for OUT3A and OUT3B. Connect to 1.8V or 2.5V or 3.3V
3	ST3/OE3	Standby or Output Enable pin for OUT3A and OUT3B.
5	OUT2B	1 to 220 MHz programmable clock output at VDD2 level (1.8V or 2.5V or 3.3V) or No Connect
6	VDD2	Power supply for OUT2A and OUT2B. Connect to 1.8V or 2.5V to 3.3V
7	OE2	Output Enable pin for OUT2A and OUT2B
9	OUT1B	1 to 220 MHz programmable clock output at VDD1 level (1.8V or 2.5V or 3.3V) or No Connect
10	VDD1	Power supply for OUT1A and OUT2A. Connect to 1.8V or 2.5V or 3.3V
11	ST3/OE3	Standby or Output Enable pin for OUT3A and OUT3B
14	GND1	VDD1 power supply ground. Connect to Ground
15	OUT1A	1 to 220 MHz programmable clock output at VDD1 level (1.8V or 2.5V or 3.3V) or No Connect
17	GND2	VDD2 power supply ground. Connect to Ground
18	OUT2A	1 to 220 MHz programmable clock output at VDD2 level (1.8V or 2.5V or 3.3V) or No Connect
20	GND3	VDD3 power supply ground. Connect to Ground
21	OUT3A	1 to 220 MHz programmable clock output at VDD1 level (1.8V or 2.5V or 3.3V)

Pins 3,7,11

Pin #s 3,7,11 Functionality
OE (3,7,11)
H or Open; specified frequency output
L: output is high impedance
ST (3,11)
H or Open; specified frequency output
L: output is low level (weak pull down) oscillation stops

Description

The SiT9104 is a multiple factory programmable clock generator with embedded MEMS resonator. The device uses SiTime propriety MEMS technology, MEMS First, to enable a single chip solution with multiple outputs for consumer and communications applications.

The SiT9104 has three PLLs that can be programmed to generate any frequency outputs from 1 to 220 MHz.

Each PLL is connected to two output buffers that can generate up to three unrelated frequencies.

Programming Description

The SiT9104 is a factory programmable device. All the parameters in table 1 given as "Enter Data" can be programmed into the SiT9104. Both outputs generated off of the same PLL are required to have same frequency i.e. OUT1A and OUT1B should be at the same frequency since they are generated from PLL1.

Table 1.

Pin Name	PLL1				PLL2				PLL3			
	OUT1A 1-220MHz or NC	OUT1B 1-220MHz or NC	ST1/OE1	VDD1 1.8/2.5/3.3V	OUT2A 1-220MHz or NC	OUT2B 1-220MHz or NC	OE2	VDD2 1.8/2.5/3.3V	OUT3A 1-220MHz or NC	OUT3B 1-220MHz or NC	ST3/OE3	VDD3 1.8/2.5/3.3V
Pin No.	15	9	11	10	18	5	7	6	21	1	3	2
Program Value	"Enter Data"	"Enter Data"	"Enter Data"	"Enter Data"	"Enter Data"	"Enter Data"	"Enter Data"	"Enter Data"	"Enter Data"	"Enter Data"	"Enter Data"	"Enter Data"

Absolute Maximum Ratings

Attempted operation outside the absolute maximum ratings of the part may cause permanent damage to the part. Actual performance of the IC is only guaranteed within the operational specifications, not at absolute maximum ratings.

Absolute Maximum Table

Parameter	Min.	Max.	Unit
Storage Temperature	-65	150	°C
VDD	-0.5	+3.6	V
Electrostatic Discharge		2000	V
Theta JA (with copper plane on VDD and GND), center pad solderded down	–	27.5	°C/W
Theta JC (with PCB traces of 0.010 inch to all pins), center pad solderded down	–	47	°C/W
Soldering Temperature (follow standard Pb free soldering guidelines)		260	°C
Number of Program Writes		1	NA
Program Retention over -40 to 125°C, Process, VDD (0 to 3.6V)		1,000+	years

Operating Conditions

Parameter	Min.	Typ.	Max.	Unit
Supply Voltages, VDD ^[1]	2.97	3.3	3.63	V
	2.25	2.5	2.75	V
	1.7	1.8	1.9	V
Extended Commercial Operating Temperature	-20	-	70	°C
Industrial Operating Temperature	-40	-	85	°C
Maximum Load Capacitance	-	-	15	pF

Environmental Compliance

Parameter	Condition/Test Method
Mechanical Shock	MIL-STD-883F, Method 2002
Mechanical Vibration	MIL-STD-883F, Method 2007
Temperature Cycle	MIL-STD-883F, Method 1010-65-150°C (1000 cycle)
Solderability	MIL-STD-883F, Method 2003
Moisture Sensibility Level	MSL1

Note:

- The 2.5V and 3.3V devices can operate from 2.75V to 2.97V as well, however, the data sheet parameters cannot be guaranteed. Please contact factory for more information.

DC Electrical Specifications

@VDD1,VDD2,VDD3 = 3.3V ±10%, -40 to 85°C

Parameter	Condition	Min.	Typ.	Max.	Unit
Output Voltage High	IOH = -9 mA	90	-	-	%Vdd
Output Voltage Low	IOL = 9 mA	-	-	10	%Vdd
Input Voltage High	Pins 3,7,11	70	-	-	%Vdd
Input Voltage Low	Pins 3,7,11	-	-	30	%Vdd
Operating Current	OUT1[A] = 30 MHz,OUT2[A,B], OUT3[A,B] = Off	-	-	26	mA
Operating Current	OUT1[A] = 125 MHz,OUT2[A,B], OUT3[A,B] = Off	-	-	31	mA
Standby Current	Outputs are weakly pulled down, ST[1,2,3] = GND	-	30	50	µA
Power Up Time	Time from minimum power supply voltage	-	-	10	ms

@VDD1,VDD2,VDD3 = 2.5V ±10%, -40 to 85°C

Parameter	Condition	Min.	Typ.	Max.	Unit
Output Voltage High	IOH = -7 mA	90	-	-	%Vdd
Output Voltage Low	IOL = 7mA	-	-	10	%Vdd
Input Voltage High	Pins 3,7,11	70	-	-	%Vdd
Input Voltage Low	Pins 3,7,11	-	-	30	%Vdd
Operating Current	OUT1[A] = 30 MHz,OUT2[A,B], OUT3[A,B] = Off	-	-	26	mA
Operating Current	OUT1[A] = 125 MHz,OUT2[A,B], OUT3[A,B] = Off	-	-	31	mA
Standby Current	Outputs are weakly pulled down, ST[1,2,3] = GND	-	30	50	µA
Power Up Time	Time from minimum power supply voltage	-	-	10	ms

@VDD1,VDD2,VDD3 = 1.8V ±5%, -40 to 85°C

Parameter	Condition	Min.	Typ.	Max.	Unit
Output Voltage High	IOH = -5 mA	90	-	-	%Vdd
Output Voltage Low	IOL = 5 mA	-	-	10	%Vdd
Input Voltage High	Pins 3,7,11	70	-	-	%Vdd
Input Voltage Low	Pins 3,7,11	-	-	30	%Vdd
Operating Current	OUT1[A] = 30 MHz,OUT2[A,B], OUT3[A,B] = Off	-	-	26	mA
Operating Current	OUT1[A] = 125 MHz,OUT2[A,B], OUT3[A,B] = Off	-	-	31	mA
Standby Current	Outputs are weakly pulled down, ST[1,2,3] = GND	-	30	50	µA
Power Up Time	Time from minimum power supply voltage	-	-	10	ms

AC Electrical Specifications

@VDD1,VDD2,VDD3 = 3.3V ±10%, -40 to 85°C

Parameter	Condition	Min.	Typ.	Max.	Unit	
Clock Output Frequency	All the outputs	1	–	220	MHz	
Frequency Stability	Inclusive of initial tolerance, operating temp., rated power supply voltage change, load change	-20 to 70°C -40 to 85°C	-25	–	+25	PPM
			-50	–	+50	PPM
Aging	First year @ 25°C	–	–	1	PPM	
Clock Output Duty Cycle	Output frequency= 1 MHz to 220 MHz	45	–	55	%	
Clock Output Rise Time	15 pF Load, 20% to 80% VDD	–	1	1.5	ns	
Clock Output Fall Time	15 pF Load, 80% to 20% VDD	–	1	1.5	ns	
RMS Period Jitter	OUT1A,OUT2A, OUT3A = 75 MHz	–	2.6	4	ps	
	OUT1A,OUT2A, OUT3A = 125 MHz	–	2.4	3.6	ps	
RMS Phase Jitter (Random)	OUT1A = 75 MHz (900 kHz to 7.5 MHz)	–	0.81	–	ps	
	OUT1A = 106.25 MHz (637 kHz to 10 MHz)	–	1.64	–	ps	
	OUT1A = 125 MHz (1.875 MHz to 20 MHz)	–	0.38	–	ps	

@VDD1,VDD2,VDD3 = 2.5V ±10%, -40 to 85°C

Parameter	Condition	Min.	Typ.	Max.	Unit	
Clock Output Frequency	All the outputs	1	–	220	MHz	
Frequency Stability	Inclusive of initial tolerance, operating temp., rated power supply voltage change, load change	-20 to 70°C -40 to 85°C	-25	–	+25	PPM
			-50	–	+50	PPM
Aging	First year @ 25°C	–	–	1	PPM	
Clock Output Duty Cycle	Output frequency= 1 MHz to 220 MHz	45	–	55	%	
Clock Output Rise Time	15 pF Load, 20% to 80% VDD	–	1	1.5	ns	
Clock Output Fall Time	15 pF Load, 80% to 20% VDD	–	1	1.5	ns	
RMS Period Jitter	OUT1A,OUT2A, OUT3A = 75 MHz	–	3	6	ps	
	OUT1A,OUT2A, OUT3A = 125 MHz	–	2.8	5	ps	
RMS Phase Jitter (Random)	OUT1A = 75 MHz (900 kHz to 7.5 MHz)	–	0.87	–	ps	
	OUT1A = 106.25 MHz (637 kHz to 10 MHz)	–	1.7	–	ps	
	OUT1A = 125 MHz (1.875 MHz to 20 MHz)	–	0.41	–	ps	

@VDD1,VDD2,VDD3 = 1.8V ±5%, -40 to 85°C

Parameter	Condition	Min.	Typ.	Max.	Unit	
Clock Output Frequency	All the outputs	1	–	220	MHz	
Frequency Stability	Inclusive of initial tolerance, operating temp., rated power supply voltage change, load change	-20 to 70°C -40 to 85°C	-25	–	+25	PPM
			-50	–	+50	PPM
Aging	First year @ 25°C	–	–	1	PPM	
Clock Output Duty Cycle	Output frequency= 1 MHz to 220 MHz	45	–	55	%	
Clock Output Rise Time	15 pF Load, 20% to 80% VDD	–	1	1.5	ns	
Clock Output Fall Time	15 pF Load, 80% to 20% VDD	–	1	1.5	ns	
RMS Period Jitter	OUT1A,OUT2A, OUT3A = 75 MHz	–	7.3	14	ps	
	OUT1A,OUT2A, OUT3A = 125 MHz	–	7.1	14	ps	

@VDD1,VDD2,VDD3 = 1.8V \pm 5%, -40 to 85°C (continued)

Parameter	Condition	Min.	Typ.	Max.	Unit
RMS Phase Jitter (Random)	OUT1A = 75 MHz (900 kHz to 7.5 MHz)	–	0.85	–	ps
	OUT1A = 106.25 MHz (637 kHz to 10 MHz)	–	1.72	–	ps
	OUT1A = 125 MHz (1.875 MHz to 20 MHz)	–	1.06	–	ps

Ordering Information^[2]

Part Number	Package Description	Frequency Stability	Product Flow
SiT9104AC-2xxx	22-pin QFN	\pm 25ppm	-20°C to 70°C
SiT9104AI-2xxx	22-pin QFN	\pm 25ppm	-40°C to 85°C
SiT9104AC-3xxx	22-pin QFN	\pm 50ppm	-20°C to 70°C
SiT9104AI-3xxx	22-pin QFN	\pm 50ppm	-40°C to 85°C

Package Information^[3]

Dimension (mm)

Land Pattern (recommended) (mm)^[4]

7.0 x 5.0 x 0.85mm

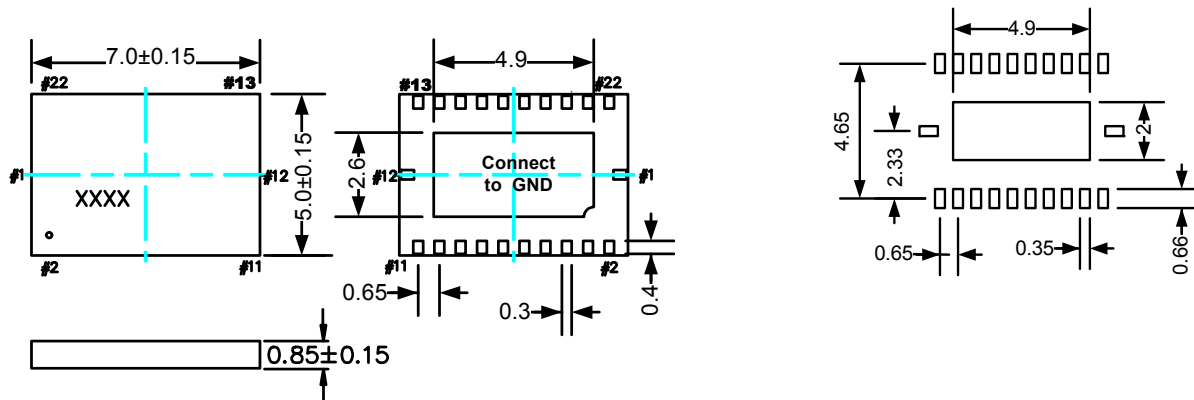

Notes:

- "xxx" denotes the assigned product dash number.
- xxxx top marking denotes manufacturing lot number.
- A capacitor of value 0.01 μ F between VDD and GND is recommended.

© SiTime Corporation 2008. The information contained herein is subject to change at any time without notice. SiTime assumes no responsibility or liability for any loss, damage or defect of a Product which is caused in whole or in part by (i) use of any circuitry other than circuitry embodied in a SiTime product, (ii) misuse or abuse including static discharge, neglect or accident, (iii) unauthorized modification or repairs which have been soldered or altered during assembly and are not capable of being tested by SiTime under its normal test conditions, or (iv) improper installation, storage, handling, warehousing or transportation, or (v) being subjected to unusual physical, thermal, or electrical stress.

Disclaimer: SiTime makes no warranty of any kind, express or implied, with regard to this material, and specifically disclaims any and all express or implied warranties, either in fact or by operation of law, statutory or otherwise, including the implied warranties of merchantability and fitness for use or a particular purpose, and any implied warranty arising from course of dealing or usage of trade, as well as any common-law duties relating to accuracy or lack of negligence, with respect to this material, any SiTime product and any product documentation. Products sold by SiTime are not suitable or intended to be used in a life support application or component, to operate nuclear facilities, or in other mission critical applications where human life may be involved or at stake. All sales are made conditioned upon compliance with the critical uses policy set forth below.

CRITICAL USE EXCLUSION POLICY
 BUYER AGREES NOT TO USE SITIME'S PRODUCTS FOR ANY APPLICATION OR IN ANY COMPONENTS USED IN LIFE SUPPORT DEVICES OR TO OPERATE NUCLEAR FACILITIES OR FOR USE IN OTHER MISSION-CRITICAL APPLICATIONS OR COMPONENTS WHERE HUMAN LIFE OR PROPERTY MAY BE AT STAKE.

SiTime owns all rights, title and interest to the intellectual property related to SiTime's products, including any software, firmware, copyright, patent, or trademark. The sale of SiTime products does not convey or imply any license under patent or other rights. SiTime retains the copyright and trademark rights in all documents, catalogs and plans supplied pursuant to or ancillary to the sale of products or services by SiTime. Unless otherwise agreed to in writing by SiTime, any reproduction, modification, translation, compilation, or representation of this material shall be strictly prohibited.